



## Caratteristiche tecniche

Technical specifications

# OUTSIDE

UNI EN ISO 14411 BIa A. G GL

---

<b>Materiale</b> Material	<b>Grès porcellanato rettificato</b> Glazed porcelain rectified
------------------------------	--------------------------------------------------------------------

---

<b>Spessore</b> Thickness	<b>20mm</b>
------------------------------	-------------

---

<b>Finitura</b> Finish	<b>Grip</b>
---------------------------	-------------

---

<b>Destinazione d'uso</b> Application	<b>Esterno / Pavimento</b> Outside / Floor
------------------------------------------	-----------------------------------------------

---



**Ceramiche Settecento Valtresinaro S.p.A.**  
Via del Crociale, 21 - 41042 Fiorano Modenese (MO)  
Tel. +39 0536 928711 - Fax +39 0536 928718  
www.settecento.com - e-mail: info@settecento.com

**SETTECENTO**  
MANIFATTURA CERAMICA



## Colori e formati · Colours and sizes

**Formato nominale**  
Nominal sizes

R11 A+B+C  $\frac{20\text{MM}}{\pm}$

**Beton**

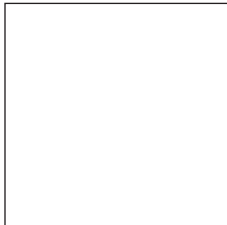

**61x61**  
24" x 24"

**Hi-Line**



**60x90**  
24" x 36"

**Plank**

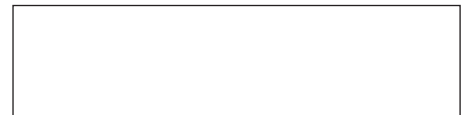

**30x121,5**  
12" x 48"

**Stone**

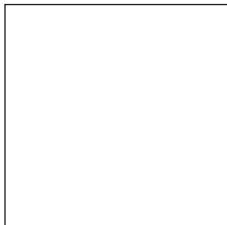

**61x61**  
24" x 24"

**Stone**

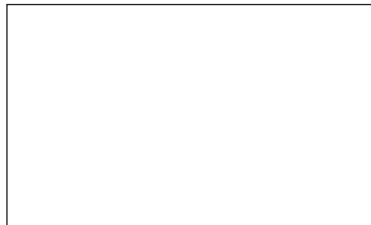

**60x90**  
24" x 36"

**Colori**  
Colours

**Beton**



Beige



Grigio



Antracite

**Hi-Line**



Sabbia



Perla



Grafite

**Stone**



Cream



Grey



Dark

**Plank**



Quercia



Pino



Cedar



Bianco



## Pezzi speciali Special Pieces

### Beton

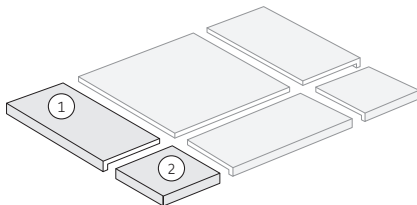

- ① **Elemento a L (lato 61)** 30x61x5  
12" x 24" x 2"
- ② **Elemento a L Angolare** 30x30x5  
12" x 12" x 2"

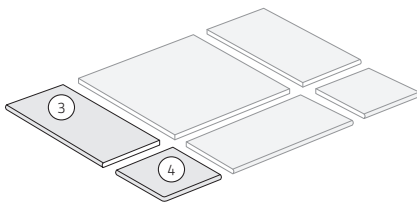

- ③ **Gradino (lato 61)** 30x61  
12" x 24"
- ④ **Gradino Angolare** 30x30  
12" x 12"

### Hi-Line

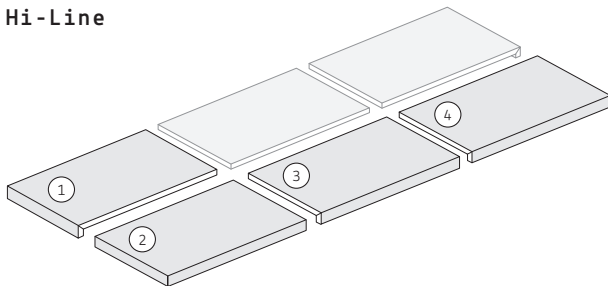

- ① **Elemento a L (lato 60)** 60x90x5  
24" x 36" x 2"
- ② **Elemento a L Angolare A** 60x90x5  
24" x 36" x 2"
- ③ **Elemento a L (lato 90)** 60x90x5  
24" x 36" x 2"
- ④ **Elemento a L Angolare B** 60x90x5  
24" x 36" x 2"

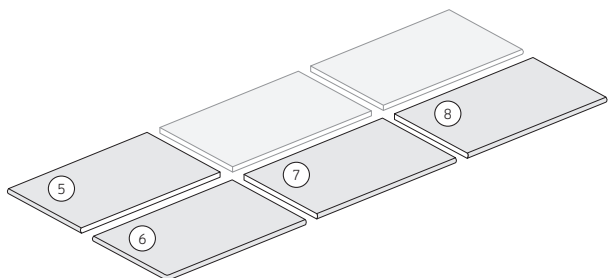

- ⑤ **Gradino (lato 60)** 60x90  
24" x 36"
- ⑥ **Gradino Angolare A** 60x90  
24" x 36"
- ⑦ **Gradino (lato 90)** 60x90  
24" x 36"
- ⑧ **Gradino Angolare B** 60x90  
24" x 36"



## Pezzi speciali Special Pieces

### Stone

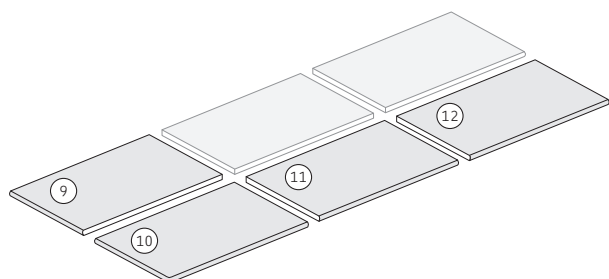
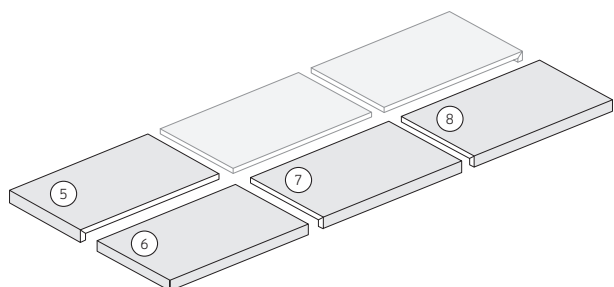
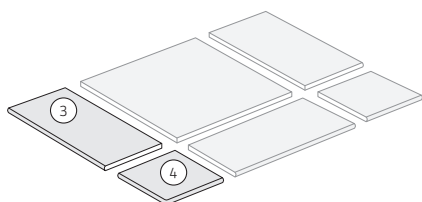
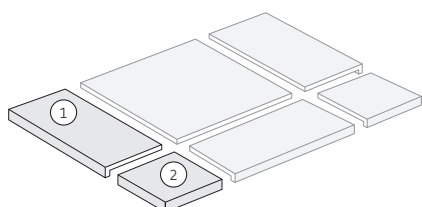

① **Elemento a L**      30x61x5  
    **(lato 61)**        12"x24"x2"

② **Elemento a L**      30x30x5  
    **Angolare**        12"x12"x2"

③ **Gradino**            30x61  
    **(lato 61)**        12"x24"

④ **Gradino**            30x30  
    **Angolare**        12"x12"

⑤ **Elemento a L**      60x90x5  
    **(lato 60)**        24"x36"x2"

⑥ **Elemento a L**      60x90x5  
    **Angolare A**      24"x36"x2"

⑦ **Elemento a L**      60x90x5  
    **(lato 90)**        24"x36"x2"

⑧ **Elemento a L**      60x90x5  
    **Angolare B**      24"x36"x2"

⑨ **Gradino**            60x90  
    **(lato 60)**        24"x36"

⑩ **Gradino**            60x90  
    **Angolare A**      24"x36"

⑪ **Gradino**            60x90  
    **(lato 90)**        24"x36"

⑫ **Gradino**            60x90  
    **Angolare B**      24"x36"



## Pezzi speciali Special Pieces

### Plank

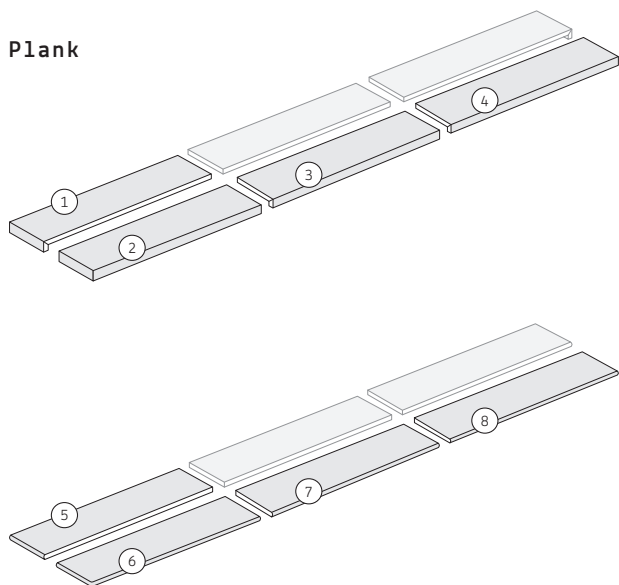

- |   |                                      |                              |
|---|--------------------------------------|------------------------------|
| ① | <b>Elemento a L<br/>(lato 30)</b>    | 30x121,5x5<br>12" x 47" x 2" |
| ② | <b>Elemento a L<br/>Angolare A</b>   | 30x121,5x5<br>12" x 47" x 2" |
| ③ | <b>Elemento a L<br/>(lato 121,5)</b> | 30x121,5x5<br>12" x 47" x 2" |
| ④ | <b>Elemento a L<br/>Angolare B</b>   | 30x121,5x5<br>12" x 47" x 2" |
| ⑤ | <b>Gradino<br/>(lato 30)</b>         | 30x121,5<br>12" x 47"        |
| ⑥ | <b>Gradino<br/>Angolare A</b>        | 30x121,5<br>12" x 47"        |
| ⑦ | <b>Gradino<br/>(lato 121,5)</b>      | 30x121,5<br>12" x 47"        |
| ⑧ | <b>Gradino<br/>Angolare B</b>        | 30x121,5<br>12" x 47"        |

## Informazioni generali · General information

**Pulizia e manutenzione**  
Cleaning and maintenance

**Usare detergenti neutri (non acidi) o alcol etilico.**  
Use neutral (non-acid) detergents or ethyl alcohol.



ITA

**Inquadra il QR Code per altre informazioni**  
Scan the QR Code for additional information



ENG

**Condizioni di vendita**  
Conditions of sale

**Come da catalogo generale · Inquadra il codice QR**  
As for general catalogue · Scan the QR Code



**Certificazioni**  
Certifications

**EPD - Dichiarazione ambientale di prodotto**  
EPD - Environmental product declaration



## Gres Porcellanato - Standard EN 14411 (ISO 13006) Annex G Group BIa (GL), E<sub>b</sub> ≤ 0,5%

Glazed porcelain / Grès cérame / Feinsteinzeug / Gres porcelánico / Керамогранит

Caratteristiche Tecniche Technical Specifications Características Técnicas Technische Eigenschaften Características Técnicas Технические Характеристики		Norme Standards Normes Normen Normas Нормы	Valore Prescritto Values Required Valeur Prescrite Normvorgabe Valor Prescrito Заданное Значение	Valore Medio Average Rating Valeur Moyenne Durchschnittswert Valor Medio Среднее Значение	
Dimensioni Sizes Dimensions Größen Dimensiones Размеры		Lunghezza e larghezza · Length and width · Dimensions des côtés · Seitenlänge Largo y ancho · Длина и ширина	ISO 10545-2	± 0,3%, max 1 mm	Conforme In accordance
		Spessore · Thickness · Epaisseur · Stärke · Espesor · Толщина		± 5%, max 0,5 mm	Conforme In accordance
		Ortogonalità · Wedging · Orthogonalité · Rechtwinkligkeit · Ortogonalidad Ортогональность		± 0,3%, max 1,5 mm	Conforme In accordance
		Rettilinearità degli spigoli · Straightness of the edges · Equerrage des angles Kantengeradheit · Rectilinearidad de las aristas · Прямолинейность углов		± 0,3%, max 0,8 mm	Conforme In accordance
		Planarità · Flatness · Plainéité · Oberflächenqualität · Planicidad · Плоскостность		± 0,4%, max 1,8 mm	Conforme In accordance
Struttura Structure Structure Struktur Estructura Структура		Assorbimento d'acqua - valore medio % · Water absorption - average value % Absorption d'eau - valeur moyenne % · Wasseraufnahme - Durchschnittswert % Absorción de agua - valor medio % · Водопоглощение Среднее значение %	ISO 10545-2 ASTM C373	≤ 0,5%	Conforme In accordance
		Sforzi di rottura · Breaking strenght · Force de rupture Bruchlast · Esfuerzo di ruptura · Усилие на излом	ISO 10545-4	S ≥ 1300 N	Conforme In accordance
		Resistenza alla flessione · Bending strength · Résistance à la flexion Biegefestigkeit Resistencia a la flexión · Прочность при изгибе		R ≥ 35 N/mm <sup>2</sup>	Conforme In accordance
		Abrasion profonda · Deep abrasion · Abrasion profonde Tiefenabrieb · Abrasión profunda · Глубокое истирание	ISO 10545-6	≤ 175mm <sup>3</sup>	Conforme In accordance
		Resistenza all'abrasione · Resistance to abrasion · Résistance à l'abrasion Abriebhärte · Resistencia a la abrasión · Стойкость к истиранию	ISO 10545-7	*1	PEI V
Sbalzi termici Thermal shock Ecart de Température Temperaturwechsel Choques térmicos Температурные Перепады		Coefficiente di dilatazione termica lineare · Coefficient of thermal linear expansion Coefficient de dilatation thermique linear · Wärmeausdehnungskoeffizient Coeficiente de dilatación termica linear · Коэффициент теплового линейного расширения	ISO 10545-8	*2	≤ 7 MK-1
		Resistenza agli sbalzi termici · Thermal shock resistance Resistance aux variations thermiques · Temperaturwechselbeständigkeit Resistencia a las diferencias de temperatura · Сопротивление температурным перепадам	ISO 10545-9	Resistente Resistant	Resistente Resistant
		Resistenza al gelo · Resistance to frost · Résistance au gel · Frostbeständigkeit Resistencia al hielo · Морозостойчивость	ISO 10545-12	Resistente Resistant	Resistente Resistant
Sicurezza Safety Sécurité Sicherheit Seguridad Безопасность		Coefficiente di attrito dinamico · Dynamic friction coefficient Coefficient de frottement dynamique · Dynamischer Reibungskoeffizient · Coeficiente de fricción dinámico · Динамический коэффициент трения	DCOF BOT 3000	Slip resistant ≥ 0,42	Conforme In accordance
		Coefficiente di attrito dinamico · Dynamic friction coefficient Coefficient de frottement dynamique · Dynamischer Reibungskoeffizient · Coeficiente de fricción dinámico · Динамический коэффициент трения	DIN 51130	*3	R11
		Classificazione antiscivolo · Non-slip classification · Classification antiderapant Bewertungsgruppe trittsicherheit · Clasificación antideslizante · Классификация противоскольжения	DIN 51097	*4	A+B+C
Resistenza chimica Chemical resistance Résistance aux attaques chimiques Chemikalienfestigkeit Resistencia a los productos químicos Химическая стойкость		Resistenza ai prodotti chimici di uso domestico e agli additivi per piscina Resistance to household chemicals and swimming pool salts · Résistance aux produits chimiques à usage domestique et aux adjuvants pour piscines · Beständigkeit gegen Haushaltchemikalien und Badewasserzusätze · Resistencia a los productos químicos de uso domestico o productos para la piscina · Сопротивляемость химическим средствам домашнего применения и добавкам для бассейна	ISO 10545-13	A	Conforme In accordance
		Resistenza a basse concentrazioni di acidi ed alcali · Resistance to low concentrations of acids and alkalis · Résistance aux acides et aux alcalis à basse concentration · Beständigkeit gegen niedrigkonzentrierte Säuren und Laugen · Resistencia a concentración baja de ácidos y álcali · Сопротивляемость кислотам и щелочам низкой концентрации		A	Conforme In accordance
		Resistenza alle macchie · Stain resistance · Résistance aux taches · Beständigkeit gegen Fleckenbildung · Resistencia a las manchas · Стойкость к загрязнению	ISO 10545-14	*5	5

\*1 \*2 \*5

Metodo di prova disponibile  
Test method available  
Méthode d'essai disponible  
Verfügbare Prüfmethode  
Método de prueba disponible  
Доступный метод испытания

\*3

In funzione dell'ambiente o della zona di lavoro  
According to the space or the working area  
Selon le lieu concerné ou la zone de travail  
Je nach Raum oder Arbeitszone  
Según el ambiente o de la zona de trabajo  
В зависимости от среды или рабочей зоны

\*4

In funzione delle zone bagnate soggette a calpestio a piedi nudi  
According to the wet area to be stepped on barefoot  
Selon le type de surface mouillée parcourue pieds nus.  
Je nach Nassbereich die barfuß zu betreten sind  
Según de la zona mojada que se pisa con los pies desnudos  
С учётом увлажняемых зон, предназначенных для ходьбы босиком